

Running outlet BI-SYSTEM for gutter profile 116

BI-SYSTEM

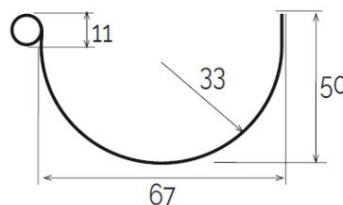

GSN116M

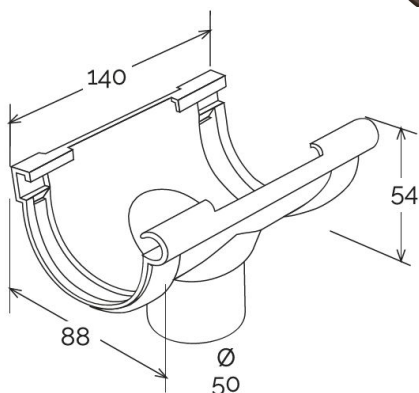

Section GRN116

Item	Colour	length mm	width mm	height mm	Weight g	Matched gutter profile	Certification IIP UNI EN 607:2023
GSN116B	white	88	140	101	102	GRN116B	✓
GSN116M	brown	88	140	101	102	GRN116M	✓
GSN116N	grey	88	140	101	102	GRN116N	✓
GSN116S	sand	88	140	101	102	GRN116S	✓

Material: PVC-U

Features:

The BI-SYSTEM joint can be used whether glued or fitted with gasket.

GLUING: The joint must be glued to the gutter by inserting it into the specific sockets. Clean the surfaces, then use PVC sealant glue (COFxxx).

FITTING: Clean the surfaces, then place the adhesive gasket (GU12) into its specific slot. Insert the gutter into the specific sockets.

