

## Stopend for gutter profile ø 125 **STEEL**

**STEEL**

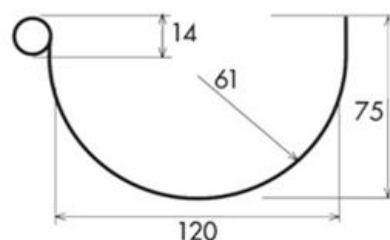
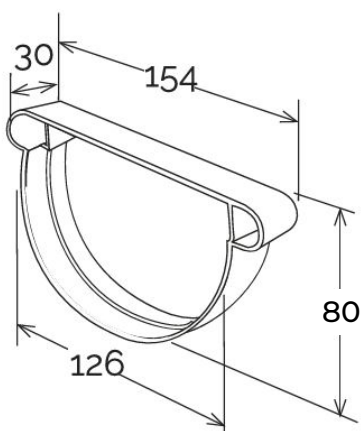
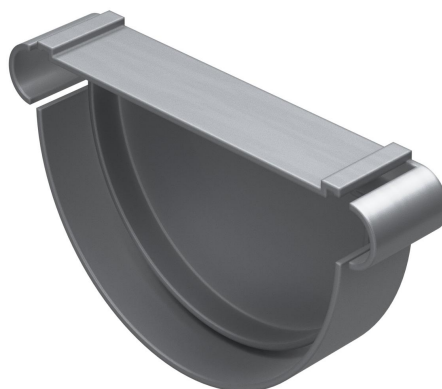

Section GRN125

Item	Colour	length mm	width mm	height mm	Weight g	Matched gutter profile
TN125AC	steel effect	154	30	80	50	GRN125AC

**Material:** Technopolymers

**Features:** The stopend must be glued to the gutter by inserting it into the specific socket. Clean the surfaces, then use PVC sealant glue (COFxxx).



## Stopend for gutter profile $\varnothing$ 125 **CUPRAELITE**

**CUPRAELITE**

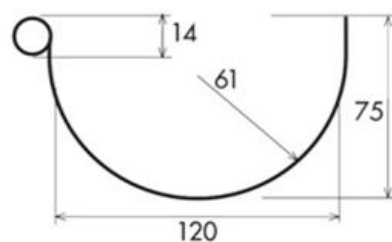
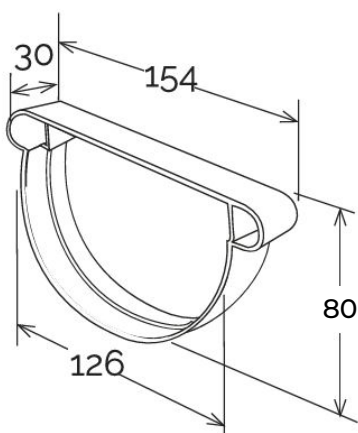
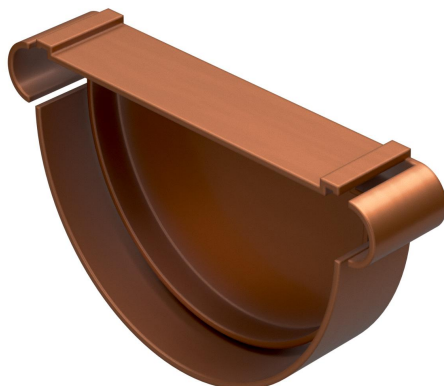

Section GRN125

Item	Colour	length mm	width mm	height mm	Weight g	Matched gutter profile
TN125R	copper effect	154	30	80	50	GRN125R

**Material:** Technopolymers

**Features:** The stopend must be glued to the gutter by inserting it into the specific socket. Clean the surfaces, then use PVC sealant glue (COFxxx).



## Stopend for gutter profile $\varnothing$ 125

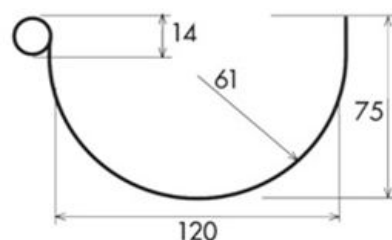
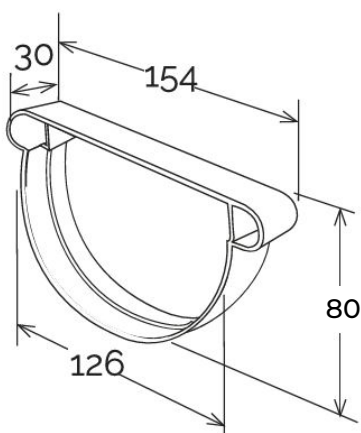
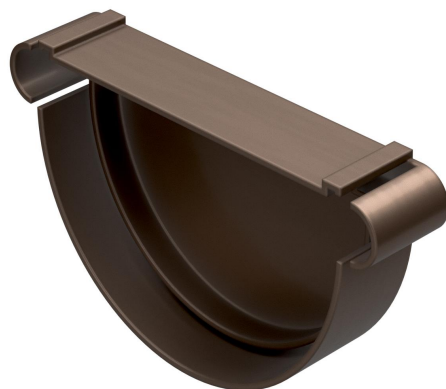

Section GRN125

Item	Colour	length mm	width mm	height mm	Weig ht g	Matched gutter profile
TN125RA	antique copper effect	154	30	80	50	GRN125RA

**Material:** Technopolymers

**Features:** The stopend must be glued to the gutter by inserting it into the specific socket. Clean the surfaces, then use PVC sealant glue (COFxxx).

